



IMAGENEX MODEL 881L-GS GYRO STABILIZED MULTI-FREQUENCY IMAGING SONAR

APPLICATIONS:

- ROV, AUV, & UUV
- Manned Submersibles
- Search & Recovery
- Borehole/cave work
- Drop sonar
- Scientific Research

FEATURES:

- **Ethernet**
- Programmable (format available)
- Gyro stabilized transducer steering
- Simple set-up and installation
- Full scale range from 1 m to 200 m
- Orientation module

Gyro-stabilization of the Imagenex Model 881L-GS makes the high resolution 881L sonar into a system capable of crystal clear visualization of the ocean environment from moving platforms, no longer compromised by the blurring effects of host vehicle rotation. An advanced, low drift gyro is integrated directly into the sonar head, so the sonar can now compensate for vehicle motion in real time with unprecedented accuracy, stability, and robustness.

The enhanced capabilities of the 881L-GS have not compromised the performance of the 881L sonar. Using Ethernet communications, this all-in-one, high performance digital imaging sonar can still exceed 100 shots per second on short range at up to 2 mm range resolution, and can auto-adjust acoustic frequency and resolution to scan up to a 200 m radius, 360° surrounding area.

The Model 881L-GS still has low power, simple set-up, and small size that make it an ideal tool for large work ROV's and small inspection vehicles. On it's own it is now an amazingly simple drop sonar and borehole inspection package: just add a laptop computer and power supply and run the included Imagenex software.



HARDWARE SPECIFICATIONS:	
FREQUENCY	310 kHz, 675 kHz, or 1 MHz (standard default settings) -Other frequencies can be selected through programmable software configurations (Tunable from 280 kHz to 1.1 MHz in 5 kHz steps)
TRANSDUCER	Imaging type, fluid compensated
TRANSDUCER BEAM WIDTH	310 kHz: 4° x 40° 675 kHz: 1.8° x 20° 1 MHz: 0.9° x 10°
RANGE RESOLUTION	1 m – 4 m: 2 mm (0.08") 5 m & up: 10 mm (0.4")
ORIENTATION MODULE (accuracies):	
PITCH & ROLL	± 0.1° typical
HEADING (Magnetic)	± 1.0° typical
MIN. DETECTABLE RANGE	150 mm (6")
MAX. OPERATING DEPTH	1000 m and 3000 m available
MAX. CABLE LENGTH	Standard: 100 m on CAT5e Cable length may be increased up to ~9000 m using an Ethernet extender. Please enquire for more information.
INTERFACE	Standard: 10 Mbps Ethernet (10 BASE-T) using TCP/IP Bit rate may vary if an Ethernet extender is in use.
CONNECTOR	Side mounted, eight conductor, wet mateable (Subconn MCBH8M-AS) Optional right angle or end mount connector
POWER SUPPLY	20 – 32 VDC at less than 7 Watts
DIMENSIONS (for both depths)	79.5 mm (3.13") diameter x 245.7 mm (9.68") length
WEIGHT: In Air	1000 m unit: 1.8 kg (4 lbs) 3000 m unit: TBA
In Water	1000 m unit: TBA 3000 m unit: TBA
MATERIALS	1000 m unit: 6061-T6 Aluminum & Polyurethane 3000 m unit: Titanium, Polyurethane & 300 series stainless steel
FINISH	Hard Anodize

SOFTWARE SPECIFICATIONS:	Win881AL.exe
WINDOWS™ OPERATING SYSTEM	Windows™ XP, Vista, 7, 8, 10
MODES	Sector, Polar and Side Scan
GYRO MODES	North Up, Heading Up, Target Steering
RANGE SCALES	1 m, 2 m, 3 m, 4 m, 5 m, 10 m, 20 m, 30 m, 40 m, 50 m, 60 m, 80 m, 100 m, 150 m, 200 m
TRAIN ANGLES	Continuous rotation, 3° increments
SECTOR SIZE: SECTOR MODE POLAR MODE	0° – 180°, 3° increments 0° – 357°, 3° increments, or Continuous rotation
STEP SIZES	Slow (0.3°), Medium (0.6°), Fast (0.9°), Faster (1.2°), Fastest (2.4°)
GRID TYPES	Polar and rectangular
FILE FORMAT	(filename).81R
RECOMMENDED MINIMUM COMPUTER REQUIREMENTS:	2 GHz Pentium 4 256 MB RAM 20 GB Hard Disk 1024 x 768 Screen Resolution

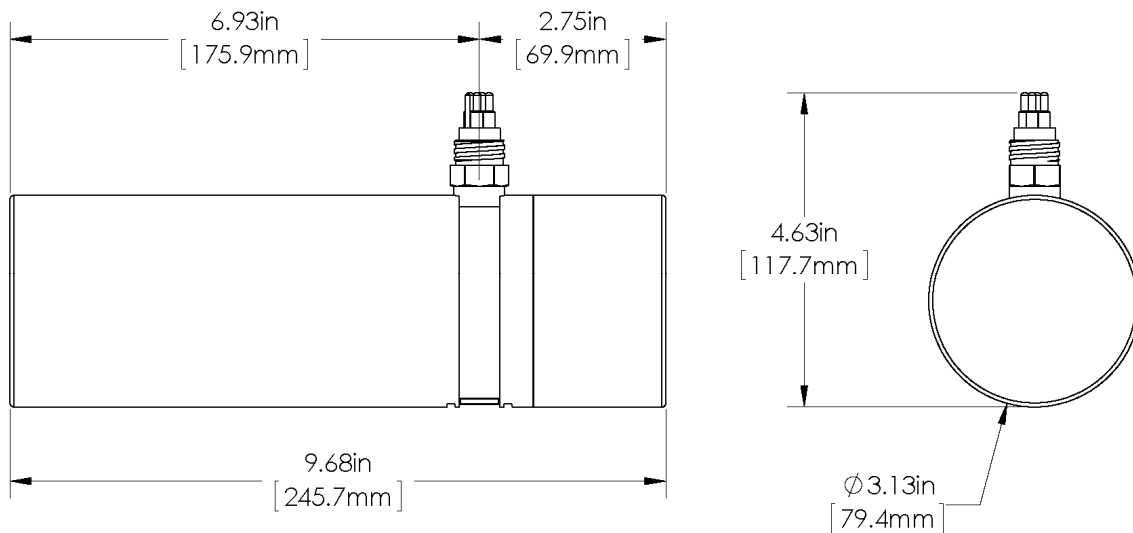

ORDERING INFORMATION:		
1000 m UNIT	Standard	881-000-500
3000 m UNIT	Standard	881-000-501
End mount connector	Option	-009
Right angle connector	Option	-010
IP Address*	Option	-020
Gyro Stabilization	Option	-048

*Note: Standard IP Address is 192.168.0.5
A different IP Address may be specified upon ordering.

Product and company names listed are trademarks or trade names of their respective companies.

TAE KWANG ELECTRONICS CORPORATION
5TH FLR., K-BLDG., 3, SANGAM-RO 41-GIL,
GANGDONG-GU, SEOUL 05307, KOREA

T PHONE : 02 479 2703
F FAX : 02 479 2705
E e-mail : taekwang@tkec.co.kr
W http://www.tkec.co.kr