



881A Imaging Narrow Beam
445-075 JANUARY 2011-REVISED MAY 2017

IMAGENEX MODEL 881A NARROW BEAM DIGITAL IMAGING SONAR

APPLICATIONS:

- ROV, AUV, & UUV
- Offshore Oil & Gas
- Sunken Timber Recovery
- Diving Support
- Surveying
- Search & Recovery
- Inspection
- Underwater Archaeology
- Scientific Research

FEATURES:

- Serial Communications
- Programmable
- High performance
- Lower cost
- Low power
- Simple set-up and installation
- Digital telemetry
- Full scale range from 1 m to 100 m
- Compact size
- Communication format available to user

Using Serial communications, this all-in-one, high performance digital imaging sonar can exceed 35 shots per second on the 1 m range at a 2 mm range resolution, producing near-photographic image quality.

The 881A can operate with customized configurations or revert to default settings to match appropriate operating range scales.

In addition to the benefits of low power, a simple set-up and installation procedure make this powerful sonar an ideal tool for remotely operated platforms ranging from large work ROV's to small inspection vehicles, as well as AUV and UUV applications.



HARDWARE SPECIFICATIONS:	
FREQUENCY	675 kHz
TRANSDUCER	Imaging type, fluid compensated
TRANSDUCER BEAM WIDTH	0.75° x 20°
RANGE RESOLUTION	1 m – 4 m: 2 mm (0.08") 5 m & up: 10 mm (0.4")
MIN. DETECTABLE RANGE	150 mm (6")
MAX. OPERATING DEPTH	1000 m
MAX. CABLE LENGTH	1000 m on typical twisted shielded pair (RS-485)
INTERFACE	RS-485 serial interface @ 115.2 kbps (or optional RS-232)
CONNECTOR	End mounted, four conductor, wet mateable (Subconn MCBH4M-AS)
POWER SUPPLY	20 – 36 VDC at less than 5 Watts
DIMENSIONS	See drawing p. 3
WEIGHT: In Air	~ 2.6 kg (6 lbs)
In Water	~ 0.9 kg (1.9 lbs)
MATERIALS	6061-T6 Aluminum & Polyurethane
FINISH	Hard Anodize

SOFTWARE SPECIFICATIONS:	Win881A.exe, Win881AL.exe
WINDOWS™ OPERATING SYSTEM	Windows™ XP, Vista, 7, 8, 10
MODES	Sector, Polar and Side Scan
RANGE SCALES	1 m, 2 m, 3 m, 4 m, 5 m, 10 m, 20 m, 30 m, 40 m, 50 m, 60 m, 80 m, 100 m
TRAIN ANGLES	Continuous rotation, 3° increments
SECTOR SIZE: SECTOR MODE POLAR MODE	0° – 180°, 3° increments 0° – 357°, 3° increments, or Continuous rotation
STEP SIZES	Slow (0.3°), Medium (0.6°), Fast (0.9°), Faster (1.2°), Fastest (2.4°)
GRID TYPES	Polar and rectangular
FILE FORMAT	(filename).81a
RECOMMENDED MINIMUM COMPUTER REQUIREMENTS:	100 MHz Pentium 16 MB RAM 1 GB Hard Disk 800 x 600 x 256 colour graphics

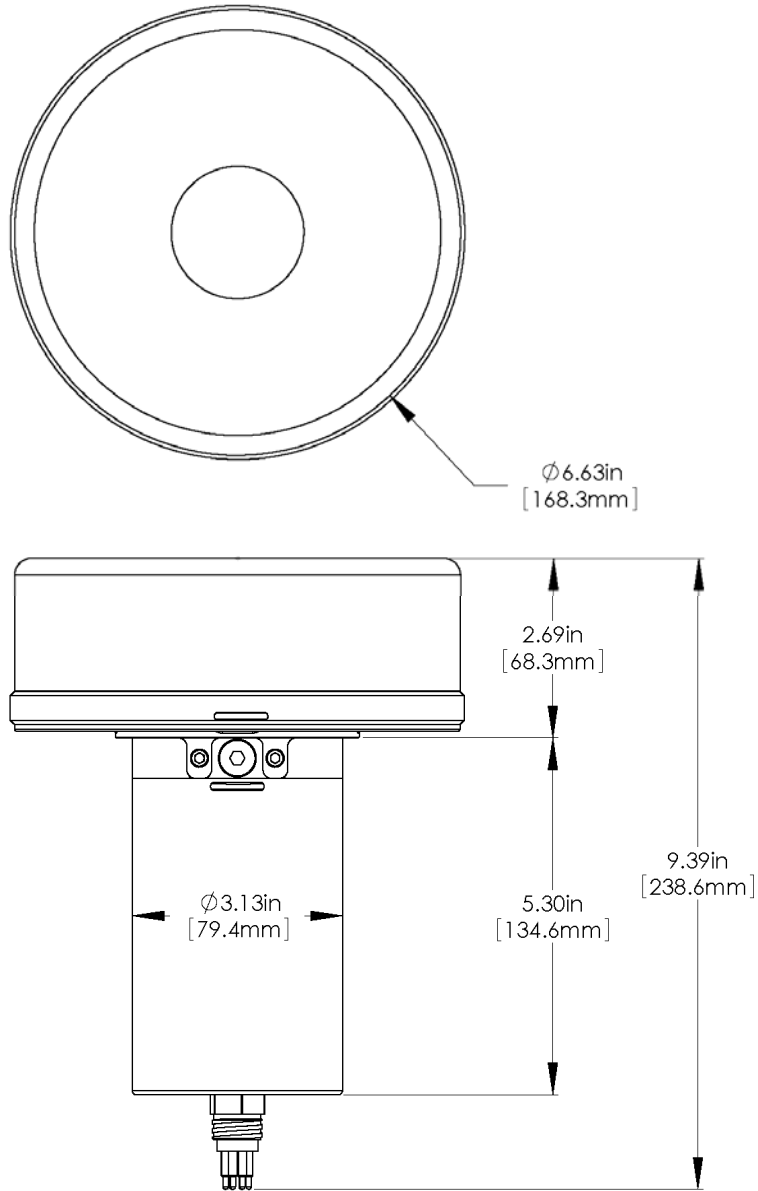

**ORDERING
INFORMATION:**

1000 m UNIT

Standard

881-000-405

Product and company names listed are trademarks or trade names of their respective companies.

TAE KWANG ELECTRONICS CORPORATION
 5TH FLR., K-BLDG., 3, SANGAM-RO 41-GIL,
 GANGDONG-GU, SEOUL 05307, KOREA

T PHONE : 02 479 2703
F FAX : 02 479 2705
E e-mail : taekwang@tkec.co.kr
W http://www.tkec.co.kr