



852 Ultra-Miniature

445-027 AUGUST 2004-REVISED MAY 2017

## IMAGENEX MODEL 852 ULTRA-MINIATURE SCANNING SONAR

### APPLICATIONS:

- ROV Navigation
- Diving Support
- Inspection
- Search & Recovery

### FEATURES:

- Ultra-miniature size is ideal for mounting on today's micro ROV's
- Continuous rotation
- Low cost
- Direct connection to laptop computer

The Model 852 Digital Imaging Sonar was designed for use with the smallest of ROV's. For maximum flexibility, this is a design with a fluid filled front end and a pressure housing for the electronics. The unit requires approximately 2.5 Watts from 24 VDC, or optional 48 VDC. Serial communication is utilized, RS-485 or RS-232 at 115.2 kbps. This unit will scan a maximum of 360° with a maximum range of 50 meters. The total weight in water is less than 0.2 kg (0.4 lbs).



<b>HARDWARE SPECIFICATIONS:</b>	
<b>FREQUENCY</b>	675 / 850 kHz
<b>TRANSDUCER</b>	Imaging type, fan beam, fluid compensated
<b>TRANSDUCER BEAM WIDTH</b>	2.5° x 22°
<b>TRANSMIT PULSE LENGTH</b>	100 microseconds
<b>RANGE RESOLUTION</b>	20 mm
<b>MIN. DETECTABLE RANGE</b>	150 mm
<b>MAX. OPERATING DEPTH</b>	300 m
<b>MAX. CABLE LENGTH</b>	1000 m on typical twisted shielded pair
<b>INTERFACE</b>	RS-485 @ 115.2 kbps (RS-232 optional)
<b>CONNECTOR</b>	IE55-1206-BCR Penetrator
<b>POWER SUPPLY</b>	22 – 30 VDC at less than 3.6 Watts Optional 40 – 56 VDC
<b>DIMENSIONS</b>	See drawing
<b>WEIGHT: In Air</b>	~270 g (0.6 lbs)
<b>In Water</b>	with 24" pigtail less than 200 g (0.4 lbs)
<b>MATERIALS</b>	6061-T6 Aluminum & Polyurethane
<b>FINISH</b>	Hard Anodize

<b>SOFTWARE SPECIFICATIONS:</b>	<b>Win852.exe</b>
<b>WINDOWS™ OPERATING SYSTEM</b>	Windows™ XP, Vista, 7, 8, 10
<b>MODES</b>	Polar, Sector, and Sidescan
<b>RANGE SCALES</b>	5 m, 10 m, 20 m, 30 m, 40 m, 50 m
<b>SECTOR SIZE:</b>	
<b>SECTOR MODE</b>	0° – 180°, 18° increments
<b>POLAR MODE</b>	360°, continuous
<b>STEP SIZES</b>	Normal (2.25°), Fast (4.5°)
<b>GRID TYPE</b>	Polar
<b>EXTERNAL INPUT</b>	Depth, Heading, Turns
<b>FILE FORMAT</b>	(filename).852
<b>RECOMMENDED MINIMUM COMPUTER REQUIREMENTS:</b>	100 MHz Pentium 16 MB RAM 1 GB Hard Disk 800 x 600 x 256 colour graphics

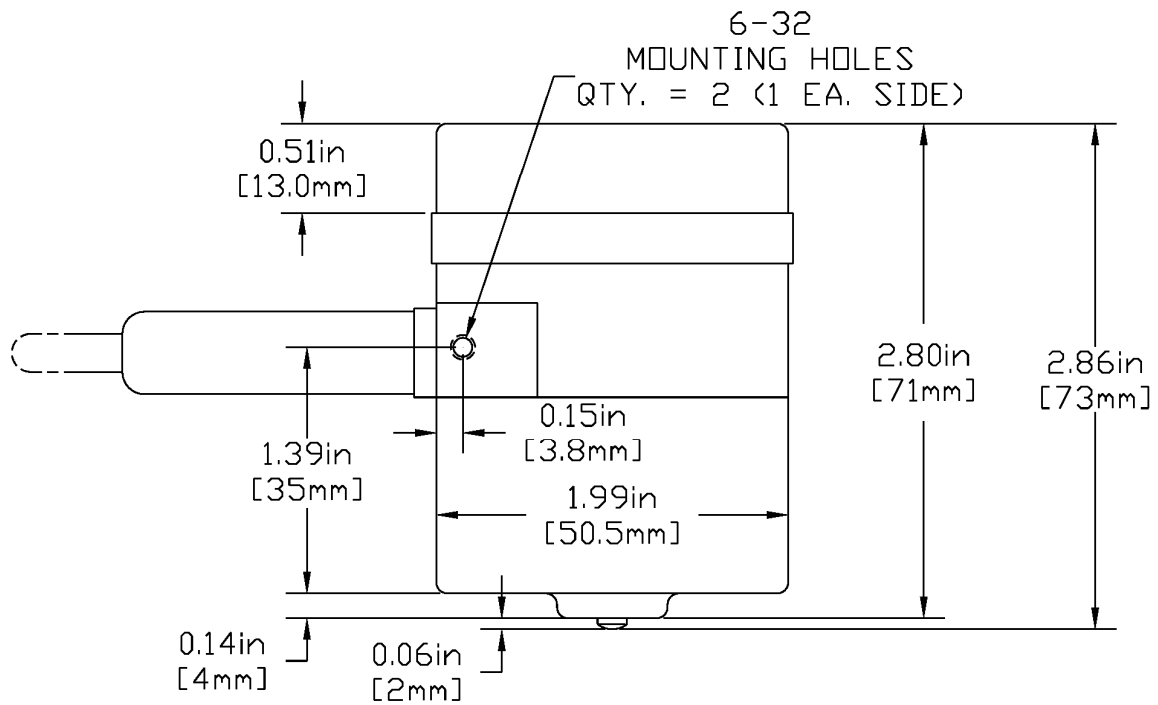
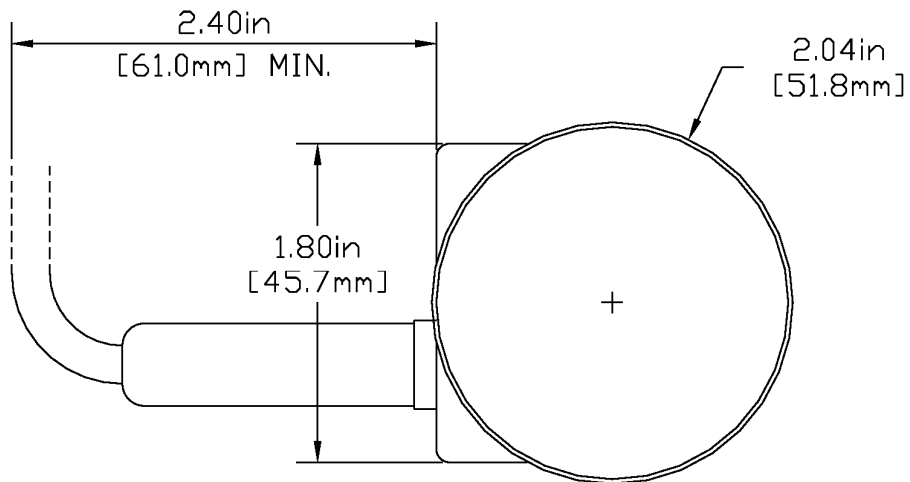

<b>ORDERING INFORMATION:</b>		
<b>300 m UNIT</b>	Standard	852-000-100
RS-232	Option	-006
40 – 56 VDC	Option	-013

Product and company names listed are trademarks or trade names of their respective companies.

**TAE KWANG ELECTRONICS CORPORATION**  
5TH FLR., K-BLDG., 3, SANGAM-RO 41-GIL,  
GANGDONG-GU, SEOUL 05307, KOREA

**T** PHONE : 02 479 2703  
**F** FAX : 02 479 2705  
**E** e-mail : taekwang@tkec.co.kr  
**W** http://www.tkec.co.kr