



IMAGENEX MODEL 852 ULTRA-MINIATURE ECHO SOUNDER

APPLICATIONS:

- ROV Navigation
- Diving Support
- Inspection
- Search & Recovery

FEATURES:

- Ultra-miniature size is ideal for mounting on today's micro ROV's
- Low cost
- Direct connection to laptop computer

The Model 852 Digital Echo Sounder was designed for use with the smallest of ROV's. For maximum flexibility, the unit requires approximately 1.5 Watts from 24 VDC, or optional 48 VDC. Serial communication is utilized, RS-485 or RS-232 at 115.2 kbps. The maximum operating range is 50 meters.



HARDWARE SPECIFICATIONS:	
FREQUENCY	675 kHz
TRANSDUCER	Conical
TRANSDUCER BEAM WIDTH	10°
RANGE RESOLUTION	20 mm
MIN. DETECTABLE RANGE	500 mm
MAX. OPERATING DEPTH	300 m
MAX. CABLE LENGTH	1000 m on typical twisted shielded pair
INTERFACE	RS-485 @ 115.2 kbps (RS-232 optional)
CONNECTOR	IE55-1206-BCR Penetrator
POWER SUPPLY	22 – 30 VDC at less than 1.5 Watts Optional 40 – 56 VDC
DIMENSIONS	See drawing
WEIGHT: In Air	Approx. 185 g (0.4 lbs) with 24" pigtail
In Water	TBA
MATERIALS	6061-T6 Aluminum
FINISH	Hard Anodize

SOFTWARE SPECIFICATIONS:	Win852.exe
WINDOWS™ OPERATING SYSTEM	Windows™ XP, Vista, 7, 8, 10
MODES	Echosounder
RANGE SCALES	5 m, 10 m, 20 m, 30 m, 40 m, 50 m
EXTERNAL INPUT	Depth, Heading, Turns
FILE FORMAT	(filename).852
RECOMMENDED MINIMUM COMPUTER REQUIREMENTS:	100 MHz Pentium 16 MB RAM 1 GB Hard Disk 800 x 600 x 256 colour graphics

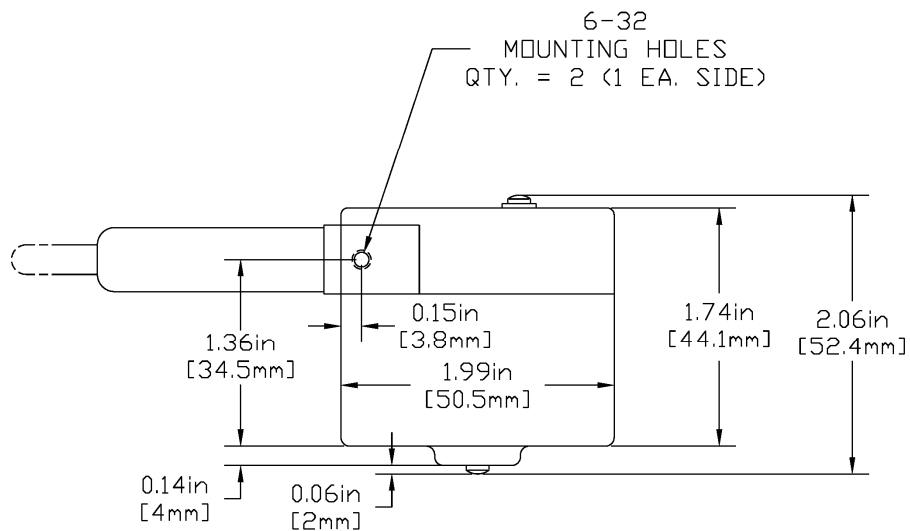
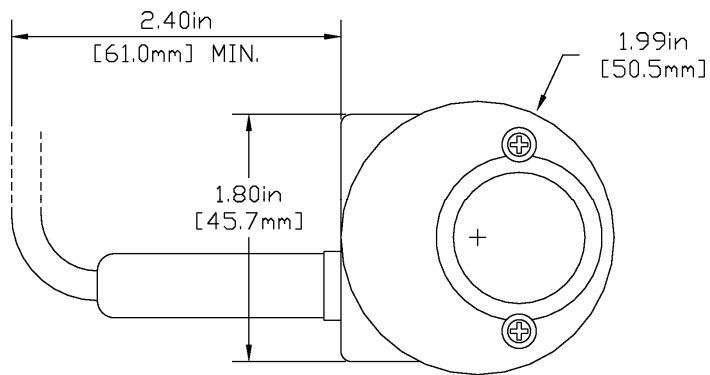

ORDERING INFORMATION:		
300 m UNIT	Standard	852-000-140
RS-232	Option	-006
40 – 56 VDC	Option	-013

Product and company names listed are trademarks or trade names of their respective companies.

TAE KWANG ELECTRONICS CORPORATION
5TH FLR., K-BLDG., 3, SANGAM-RO 41-GIL,
GANGDONG-GU, SEOUL 05307, KOREA

T PHONE : 02 479 2703
F FAX : 02 479 2705
E e-mail : taekwang@tkec.co.kr
W http://www.tkec.co.kr