

IMAGENEX MODEL 852-GS GYRO STABILIZED ULTRA-MINIATURE IMAGING SONAR

APPLICATIONS:

- ROV, AUV, & UUV
- Manned Submersibles
- Search & Recovery
- Scientific Research

FEATURES:

- Ultra-miniature size is ideal for mounting on today's micro ROV's
- Gyro stabilized transducer steering
- Daisy-chain sonar with optional echo sounder
- Simple set-up and installation
- Orientation module

The Imagenex Model 852-GS was designed for use with the smallest of ROV's and inspection vehicles. Gyro-stabilization is integrated directly into the sonar head, so the sonar is no longer compromised by the blurring effects of host vehicle rotation.

Connect the optional echo sounder to the sonar and straight to the surface.

Serial communication is utilized, RS-485 or RS-232 at 115.2 kbps. This unit will scan 360° with a maximum range of 50 meters.

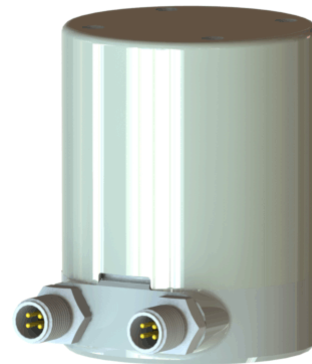
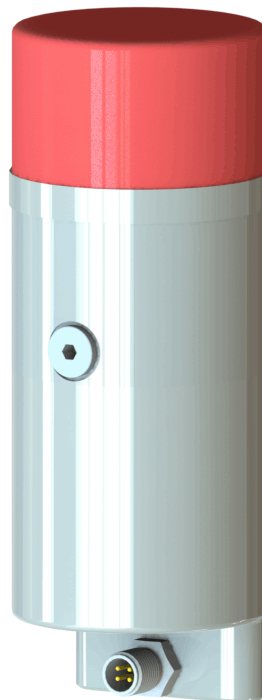

Optional Echo Sounder

HARDWARE SPECIFICATIONS:	
FREQUENCY	675 kHz
TRANSDUCER	Imaging type, fluid compensated
TRANSDUCER BEAM WIDTH	675 kHz: 2.4° x 20°
RANGE RESOLUTION	5 m & up: 10 mm (0.4") @ 500 data points or 20 mm (0.8") @ 250 data points (Polar mode)
ORIENTATION MODULE (accuracies):	
PITCH & ROLL	TBA
HEADING (Magnetic)	TBA
MIN. DETECTABLE RANGE	150 mm (6")
MAX. OPERATING DEPTH	300 m
MAX. CABLE LENGTH	1000 m on typical twisted shielded pair (RS-485)
INTERFACE	RS-485 serial interface @ 115.2 kbps (or optional RS-232)
CONNECTOR	IE55-1206-BCR
POWER SUPPLY	12 – 50 VDC at less than 3 Watts
DIMENSIONS	54.4 mm (2.14") diameter x 142.7 mm (5.62") length
WEIGHT: In Air	~0.6 kg (~1.3 lbs)
In Water	~0.3 kg (~0.7 lbs)
MATERIALS	6061-T6 Aluminum & Polyurethane
FINISH	Hard Anodize

SOFTWARE SPECIFICATIONS:	TBA
WINDOWS™ OPERATING SYSTEM	Windows™ XP, Vista, 7, 8, 10
MODES	Sector, Polar, and Side Scan
GYRO MODES	North Up, Heading Up, Target Steering
RANGE SCALES	5 m, 10 m, 20 m, 30 m, 40 m, 50 m
TRAIN ANGLES	Continuous rotation, 3° increments
SECTOR SIZE:	
SECTOR MODE	0° – 180°, 3° increments
POLAR MODE	0° – 357°, 3° increments, or Continuous rotation
STEP SIZES	Slow (0.3°), Medium (0.6°), Fast (0.9°), Faster (1.2°), Fastest (2.4°)
GRID TYPES	Polar and rectangular
FILE FORMAT	(filename).81R
RECOMMENDED MINIMUM COMPUTER REQUIREMENTS:	2 GHz Pentium 4 256 MB RAM 20 GB Hard Disk 1024 x 768 Screen Resolution

OPTIONAL ECHO SOUNDER HARDWARE SPECIFICATIONS:	
FREQUENCY	675 kHz
TRANSDUCER	Conical
TRANSDUCER BEAM WIDTH	10°
RANGE RESOLUTION	20 mm
MIN. DETECTABLE RANGE	500 mm
MAX. OPERATING DEPTH	300 m
MAX. CABLE LENGTH	1000 m on typical twisted shielded pair
INTERFACE	RS-485 @ 115.2 kbps (RS-232 optional)
CONNECTOR	IE55-1206-BCR
POWER SUPPLY	12 – 50 VDC at less than 3 Watts
DIMENSIONS	See drawing
WEIGHT: In Air	~0.23 kg (~0.5 lbs)
 In Water	~0.07 kg (~0.16 lbs)
MATERIALS	6061-T6 Aluminum
FINISH	Hard Anodize

OPTIONAL ECHO SOUNDER SOFTWARE SPECIFICATIONS:	
WINDOWS™ OPERATING SYSTEM	Windows™ XP, Vista, 7, 8, 10
MODES	Echosounder
RANGE SCALES	5 m, 10 m, 20 m, 30 m, 40 m, 50 m
EXTERNAL INPUT	Depth, Heading, Turns
FILE FORMAT	TBA
RECOMMENDED MINIMUM COMPUTER REQUIREMENTS:	2 GHz Pentium 4 256 MB RAM 20 GB Hard Disk 1024 x 768 Screen Resolution

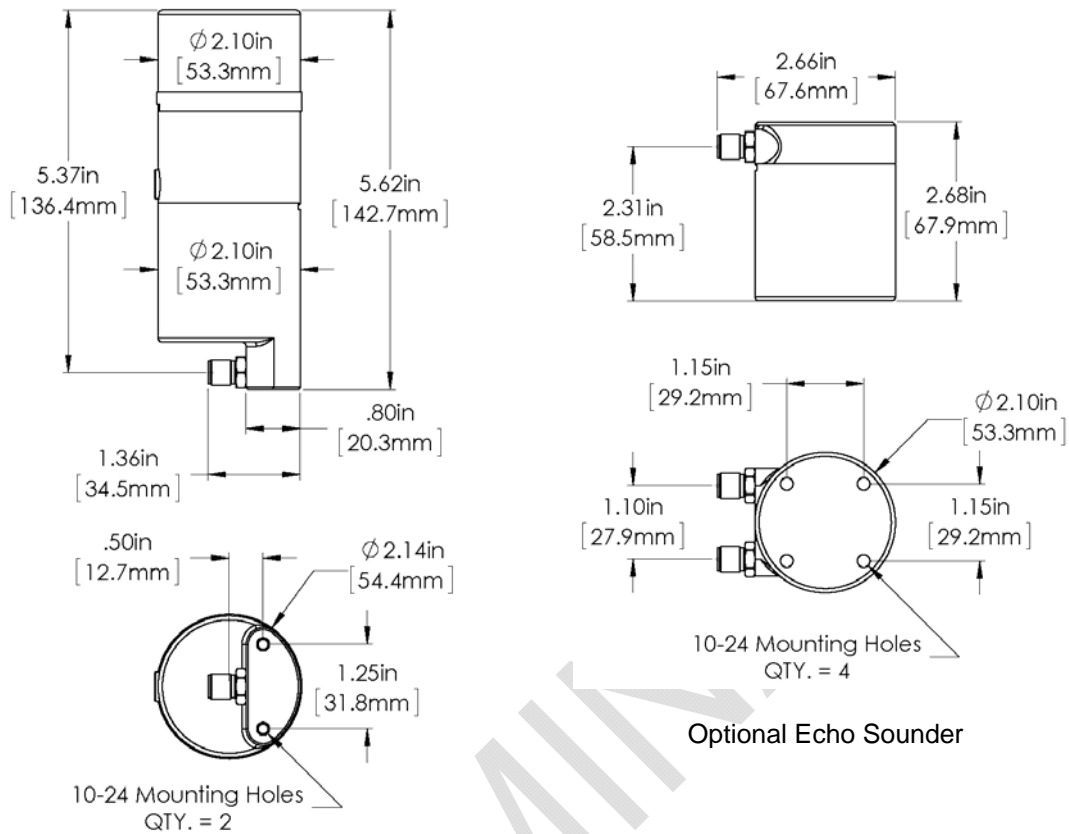

ORDERING INFORMATION:		
300 m UNIT	Standard	852-000-400
RS-232	Option	-006
External Trigger	Option	-023
Echo Sounder	Option	-053

Product and company names listed are trademarks or trade names of their respective companies.

TAE KWANG ELECTRONICS CORPORATION
 5TH FLR., K-BLDG., 3, SANGAM-RO 41-GIL,
 GANGDONG-GU, SEOUL 05307, KOREA

T PHONE : 02 479 2703
F FAX : 02 479 2705
E e-mail : taekwang@tkec.co.kr
W http://www.tkec.co.kr