



# IMAGENEX MODEL 831L DIGITAL PIPE PROFILING SONAR

### APPLICATIONS:

- Profiling
- Pipeline Inspection
- Scientific Research

### FEATURES:

- **Ethernet**
- Programmable
- High performance
- Scans 360° in 1.3 sec (up to 1 m range)
- Low power
- 0.125 m to 6 m operation (full scale)
- Compact size
- Communication format available to user
- Built in Pitch/Roll sensor



HARDWARE SPECIFICATIONS:	
FREQUENCY	2.25 MHz
TRANSDUCER	Profiling type, fluid compensated
TRANSDUCER BEAM WIDTH	1.4° conical
RANGE RESOLUTION	0.5 mm
MIN. DETECTABLE RANGE	50 mm (~ 2")
MAX. OPERATING DEPTH	1000 m
MAX. CABLE LENGTH	Standard: 100 m on CAT5e Cable length may be increased up to ~9000 m using an Ethernet extender. Please enquire for more information.
INTERFACE	Standard: 10 Mbps Ethernet (10 BASE-T) using TCP/IP Bit rate may vary if an Ethernet extender is in use.
CONNECTOR	End mounted, eight conductor, wet mateable (Subconn MCBH8M-AS)
POWER SUPPLY	20 – 32 VDC at less than 5 Watts
DIMENSIONS	61 mm (2.4") diameter x 347 mm (13.64") overall length
WEIGHT: In Air	1.2 kg (2.6 lbs)
In Water	0.4 kg (0.8 lb)
MATERIALS	6061-T6 Aluminum & Polyurethane
FINISH	Hard Anodize

<b>SOFTWARE SPECIFICATIONS:</b>	<b>PipeSonarL.exe</b>
<b>WINDOWS™ OPERATING SYSTEM</b>	Windows™ XP, Vista, 7, 8, 10
<b>MODES</b>	Polar
<b>RANGE SCALES</b>	0.125 m, 0.25 m, 0.50 m, 0.75 m, 1 m, 2 m, 3 m, 4 m, 5 m, 6 m
<b>TRAIN ANGLES</b>	Continuous rotation, 9° increments
<b>SECTOR SIZE</b>	0° – 351°, 9° increments, or Continuous rotation
<b>STEP SIZE</b>	0.9°
<b>GRID TYPES</b>	Polar and rectangular
<b>FILE FORMAT</b>	(filename).31L
<b>RECOMMENDED MINIMUM COMPUTER REQUIREMENTS:</b>	2 GHz Pentium 4 256 MB RAM 20 GB Hard Disk 1024 x 768 screen resolution

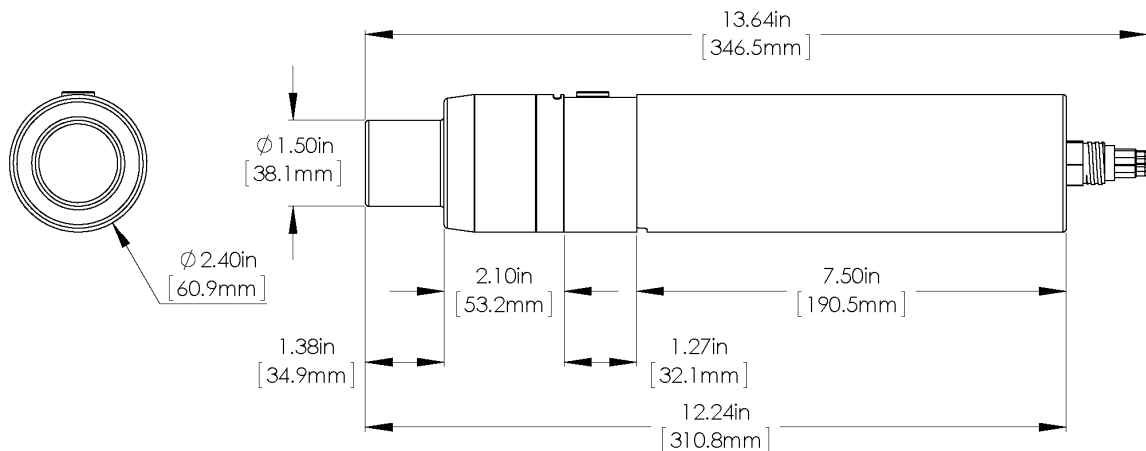

<b>ORDERING INFORMATION:</b>		
<b>1000 m UNIT</b>	Standard	831L-000-200
IP Address*	Option	-020

\*Note: Standard IP Address is 192.168.0.5  
A different IP Address may be specified upon ordering.

Product and company names listed are trademarks or trade names of their respective companies.

**TAE KWANG ELECTRONICS CORPORATION**  
5TH FLR., K-BLDG., 3, SANGAM-RO 41-GIL,  
GANGDONG-GU, SEOUL 05307, KOREA

**T** PHONE : 02 479 2703  
**F** FAX : 02 479 2705  
**E** e-mail : taekwang@tkec.co.kr  
**W** http://www.tkec.co.kr