



IMAGENEX MODEL 831A DIGITAL PIPE PROFILING SONAR

APPLICATIONS:

- Profiling
- Pipeline Inspection
- Scientific Research

FEATURES:

- Programmable
- High performance
- Scans 360° in 1 sec (up to 1 m range)
- Low power
- Digital telemetry
- 0.25 m to 6 m operation (full scale)
- Compact size
- Communication format available to user



HARDWARE SPECIFICATIONS:		
FREQUENCY	2.25 MHz	
TRANSDUCER	Profiling type, fluid compensated	
TRANSDUCER BEAM WIDTH	1.4° conical	
RANGE RESOLUTION	0.25 m: 1 mm	0.50 m: 2 mm
	0.75 m: 3 mm	1 m to 6 m: 2 mm
MIN. DETECTABLE RANGE	50 mm (~ 2")	
MAX. OPERATING DEPTH	1000 m	
MAX. CABLE LENGTH	1000 m on typical twisted shielded pair (RS-485)	
INTERFACE	RS-485 serial interface @ 115.2 kbps (or optional RS-232)	
CONNECTOR	End mounted, four conductor, wet mateable (Subconn MCBH4M-AS)	
POWER SUPPLY	20 – 36 VDC at less than 5 Watts	
DIMENSIONS	79.4 mm (3.125") diameter x 273 mm (10.73") overall length	
WEIGHT: In Air	1.4 kg (3 lbs)	
In Water	0.5 kg (1 lb)	
MATERIALS	6061-T6 Aluminum & Polyurethane	
FINISH	Hard Anodize	

SOFTWARE SPECIFICATIONS:	PipeSonar.exe
WINDOWS™ OPERATING SYSTEM	Windows™ XP, Vista, 7, 8, 10
MODES	Polar
RANGE SCALES	0.25 m, 0.50 m, 0.75 m, 1 m, 2 m, 3 m, 4 m, 5 m, 6 m
STEP SIZE	0.9°
GRID TYPES	Polar
FILE FORMAT	(filename).31A
RECOMMENDED MINIMUM COMPUTER REQUIREMENTS:	100 MHz Pentium 16 MB RAM 1 GB Hard Disk 800 x 600 x 256 colour graphics

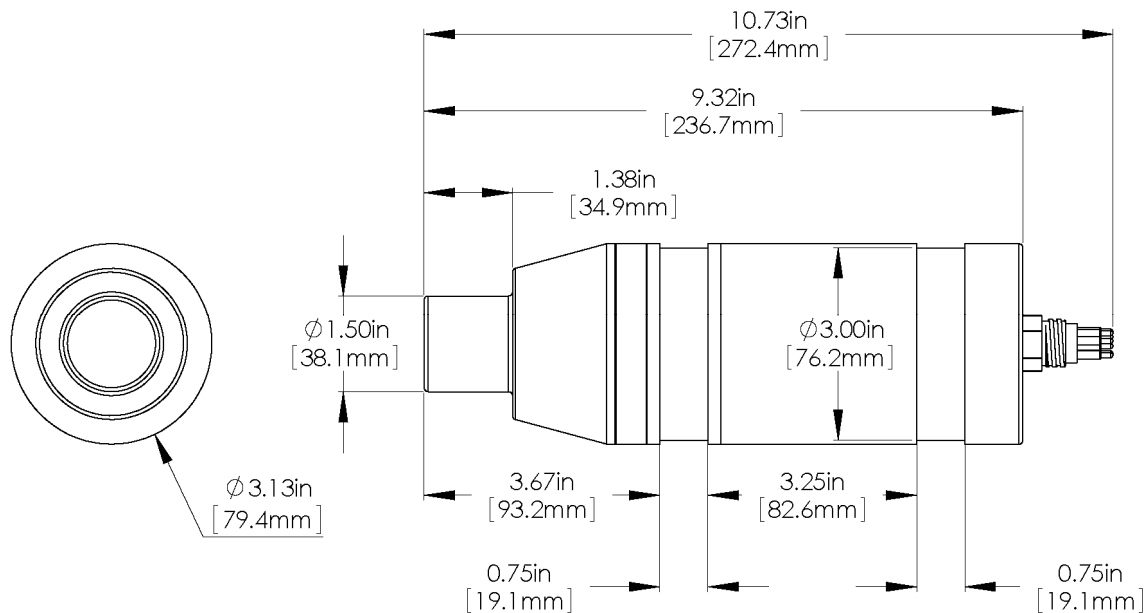

ORDERING INFORMATION:		
1000 m UNIT	Standard	831A-000-200
RS-232	Option	-006
Interface source code in "C" (TEST831A.C)	Option	-018

Product and company names listed are trademarks or trade names of their respective companies.

TAE KWANG ELECTRONICS CORPORATION
5TH FLR., K-BLDG., 3, SANGAM-RO 41-GIL,
GANGDONG-GU, SEOUL 05307, KOREA

T PHONE : 02 479 2703
F FAX : 02 479 2705
E e-mail : taekwang@tkec.co.kr
W http://www.tkec.co.kr